

VistaIntra DC

EN

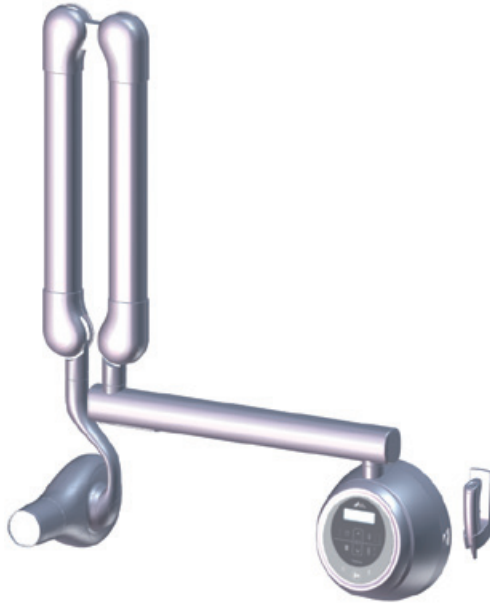

Installation and Operating Instructions

CE 2460

2202100028L02



 **DÜRR
DENTAL**

1712V017

Contents



Important information

1 About this document	2
1.1 Warnings and symbols	2
1.2 Copyright information	2
2 Safety	3
2.1 Intended use	3
2.2 Improper use	3
2.3 General safety information	3
2.4 Radiation protection	3
2.5 Qualified personnel	3
2.6 Protection from electric shock	3
2.7 Only use genuine parts	3
2.8 Transport	4
2.9 Disposal	4



Product description

3 Overview	5
3.1 Scope of delivery	6
3.2 Special accessories	6
3.3 Disposable materials	6
4 Technical data	7
4.1 X-ray tube performance data	8
4.2 Dimensions	9
4.3 Type plate	12
4.4 Conformity assessment	12
5 Operation	13
5.1 Control panel	13
5.2 Exposure switch	15
5.3 Radiation field limitation	15
5.4 Wall mounting plate	15
5.5 Adapter plate	15



Installation

6 Requirements	16
6.1 Installation/setup room	16
6.2 Information about electrical connections	16

7 Installation	17
7.1 Installing the unit with the wall mounting bracket	17
7.2 Secure unit with wall mounting plate	17
7.3 Mount radiation field collimation	17
7.4 Electrical safety when making connections	18
7.5 Connecting the unit to the mains	18
8 Commissioning and first start-up	18
8.1 Acceptance test	18
8.2 Electrical safety checks	18
8.3 Switch on the unit	18
8.4 Service menu settings	19



Operation

9 Operation	20
9.1 Standard settings after activation	20
9.2 Positioning patient, X-ray unit and detector	23
9.3 Trigger the capturing of the image	24
10 Cleaning and disinfection	25
11 Maintenance	26
11.1 Recommended maintenance schedule	26



Troubleshooting

12 Tips for operators and service technicians	27
--	----



Appendix

13 Information about EMC in accordance with EN 60601-1-2	30
13.1 General information	30
13.2 Abbreviations	30
13.3 Guidelines and manufacturer's information	30
13.4 Calculation table	34



Important information

1 About this document

These installation and operating instructions form part of the unit.

 If the instructions and information in these installation and operating instructions are not followed, Dürr Dental will not be able to offer any warranty or assume any liability for the safe operation and the safe functioning of the unit.

1.1 Warnings and symbols

Warnings

The warnings in this document are intended to draw your attention to possible injury to persons or damage to machinery.

The following warning symbols are used:

 General warning symbol

 Warning – dangerous high voltage

 Warning – X-rays

The warnings are structured as follows:



SIGNAL WORD

Description of the type and source of danger

Here you will find the possible consequences of ignoring the warning

> Follow these measures to avoid the danger.

The signal word differentiates between four levels of danger:

- **DANGER**
Immediate danger of severe injury or death
- **WARNING**
Possible danger of severe injury or death
- **CAUTION**
Risk of minor injuries
- **NOTICE**
Risk of extensive material/property damage

Other symbols

These symbols are used in the document and on or in the unit:

 Note, e.g. specific instructions regarding efficient and cost-effective use of the unit.

 Comply with the Operating Instructions.

 CE labelling with the number of the notified body

 CSA classification

 Manufacturer

 Dispose of correctly in accordance with EU Directive 2012/19/EU (WEEE).

 Date of manufacture

 Application part type B

 Authorised EU representative

 Medical device in accordance with US-FDA

 Wear hand protection.

 Switch off and de-energise the unit (e.g. unplug from mains).

1.2 Copyright information

All names of circuits, processes, names, software programs and units used in this document are protected by copyright.

The Installation and Operating Instructions must not be copied or reprinted, neither in full nor in part, without written authorisation from Dürr Dental.

2 Safety

The unit has been developed and designed in such a way that dangers are effectively ruled out if used in accordance with the proper, intended use. Nevertheless, residual risks can remain. You should therefore observe the following notes.

2.1 Intended use

This unit is designed solely for taking intraoral X-rays for the examination and diagnosis of diseases and illnesses of teeth, jaw and the oral cavity.

2.2 Improper use

Any other usage or usage beyond this scope is deemed to be improper. The manufacturer accepts no liability for damages resulting from this. In these cases the user/operator will bear the sole risk.

2.3 General safety information

The sale or prescription of this device by a medical practitioner is subject to the restrictions of the applicable Federal Acts. The device may be used only under permanent supervision of a dentist or licensed medical practitioner.

Rx_{only} Medical device in accordance with US-FDA

- › When operating this device always observe all guidelines, laws, and other rules and regulations that are applicable at the site of operation.
- › Prior to each use, check condition of the device and make sure it is in perfect working order.
- › Do not convert or modify the units.
- › Observe the Installation and Operating Instructions.
- › Make the Installation and Operating Instructions available to the person operating the device at all times.

2.4 Radiation protection

- › Comply with all applicable X-ray protection rules and take all required X-ray protection measures.
- › Use the prescribed X-ray protection equipment.
- › In order to reduce the level of X-ray exposure, we recommend the use of bismuth, lead

shielding or protective aprons, especially for children and teenagers.

- › The persons operating the equipment must keep away from the X-ray unit while the exposure is being taken. The minimum distance required by law must be maintained (e.g. Germany 1.5 m, Austria 2.0 m).
- › Children and pregnant women must consult a doctor before having an X-ray taken.
- › Nobody else must be in the radiation room without X-ray protection measures apart from the patient. In exceptional circumstances another person may be present to provide assistance, but this must not be a member of the surgery staff. When the exposure is being taken, make sure that you maintain visual contact with the patient and the unit and keep talking to the patient.
- › The radiation room must be lockable to prevent entry by unauthorised persons.
- › If a fault occurs, cancel the exposure immediately by letting go of the trigger button.

2.5 Qualified personnel

Operation

Persons who operate the units must ensure safe and correct handling based on their training and knowledge.

- › Instruct or have every user instructed in handling the unit.

Installation and repairs

- › Installation, readjustments, alterations, upgrades and repairs must be carried out by Dürr Dental or by qualified personnel specifically approved and authorized by Dürr Dental.

2.6 Protection from electric shock

- › When working on the units observe all the relevant electrical safety regulations.
- › Never touch the patient and unshielded plug connections on the device at the same time.
- › Immediately replace any damaged lines and connections.

2.7 Only use genuine parts

- › Only use Dürr Dental parts or accessories and special accessories specifically approved by Dürr Dental.
- › Only use only genuine working parts and spare parts.

2.8 Transport

The original packaging provides optimum protection for the device during transport.

If required, original packaging for the unit can be ordered from Dürr Dental.

 Dürr Dental does not accept any responsibility or liability for damage occurring during transport due to the use of incorrect packaging, even where the unit is still under guarantee.

- › Only transport the device in its original packaging.
- › Keep the packing materials out of the reach of children.

2.9 Disposal

Unit



The unit must be properly disposed of. Within the European Union, the unit must be disposed of in accordance with EU Directive 2012/19/EU (WEEE).

- › If you have any questions about the correct disposal of parts, please contact your dental trade supplier.

X-ray emitter

The X-ray unit contains a tube that is potentially capable of imploding, lead cladding and mineral oil.



3 Overview

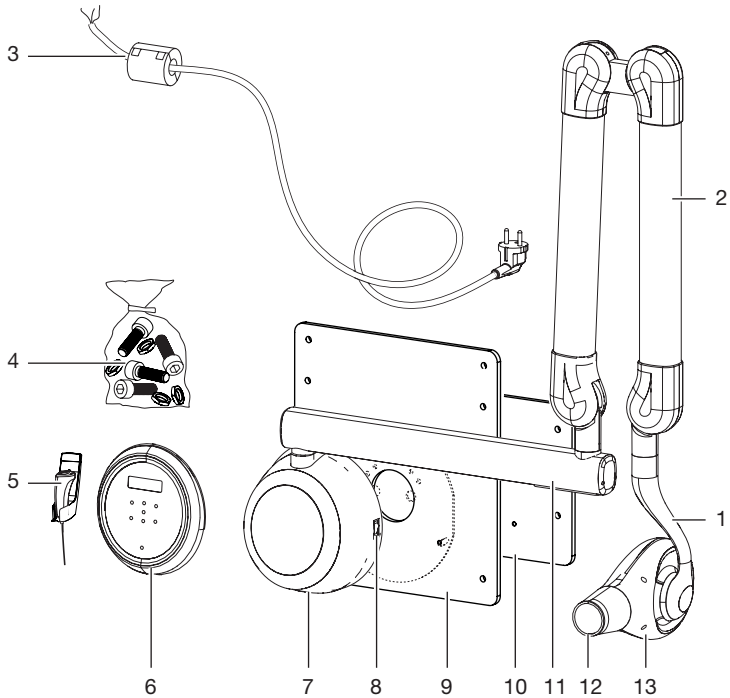

- 1 Supporting arm
- 2 Scissor arm
- 3 Mains cable with ferrite core
- 4 Small parts
- 5 Capture ring
- 6 Control panel
- 7 Control unit including wall mounting
- 8 Main power switch
- 9 Wall mounting plate (optional)
- 10 Adapter plate (optional)
- 11 Horizontal arm
- 12 Radiation field limitation
- 13 X-ray emitter

3.1 Scope of delivery

The following items are included in the scope of delivery. Possible variations due to country-specific requirements and import regulations are possible.:

VistalIntra DC X-ray unit with short extension arm 2202-01

VistalIntra DC X-ray unit with medium extension arm 2202-02

VistalIntra DC X-ray unit with long extension arm 2202-03

- X-ray emitter
- Scissor arm
- Horizontal arm
- Control unit with control panel
- Capture ring and holder
- X-ray field collimation 3 x 4
- Mains cable
- Small parts
- Ferrite core
- Installation and operating instructions
- Installation instructions
- Drill template

3.2 Special accessories

The following optional items can be used with the unit:

Set Color image plate and film holder system 2130100015

Image plate and film holder system conversion set for endo-exposures, colour 2130100014

Wall mounting plate. 2202-303-50

X-ray field collimation 2 x 3 2202-101-50

Tube extension 300 mm 2202-102-50

Cover panel without LAN cable 2202100012

Commissioning and intraoral constancy tests

Intra / Extra Digital test body 2121-060-54

Adapter plate

Sirona Heliodont MD 2202-303-52

Sirona Heliodont DS 2202-303-51

Trophy Irix/CCX 2202-303-53

Planmeca Intra 2202-303-54

Trophy Elitys 2202-303-55

KaVo Centro 2202100035

3.3 Disposable materials

Cleaning and disinfection

FD 350 Classic disinfection wipes CDF35CA0140

FD 333 rapid surface disinfectant CDF333C6150

FD 322 rapid surface disinfectant CDF322C6150

EN

4 Technical data

Electrical data for the unit		
Nominal voltage	V AC	100 - 240
Max. mains voltage fluctuation	%	±10
Frequency	Hz	50/60
Rated power	W	500
Maximum power	VA	750

Classification	
Medical product class	IIb
Manufacturer: VATECH Co., Ltd. for Dürr Dental 13, Samsung 1-ro 2-gil, Hwaseong-si, Gyeonggi-do, Korea	
Authorised EU representative Vatech Dental Manufacturing Ltd., Suite 3, Ground Floor, Chancery House, St. Nicholas Way, Sutton, SM1 1JB UK	

X-ray unit technical data		
Toshiba D-041SB (Stationary Anode Type)		
Model		DG-10A05T3
Generator		140 x 150 x 70 2.5 kg
Tube length	mm	200 (300 optional)
Generator power	kW	0.5
Nominal voltage	kVp	50 - 70 (±10 %)
Nominal current	mA	4 - 7 (±20 %)
X-ray tube cooling		Automatically controlled ≥50 °C Air cooling: Optional
Integrated filtering		1.0 mm Al
Total filtration		Min. 2.0 mm Al
Focal spot size as per IEC 60336	mm	0.4
Radiation field limitation	mm	∅ 60/30 x 40 (20 x 30 optional)
Exposure time	sec.	0.04 - 2 (± 5% or ± 20 ms)
Total filtration	mm Al	2.0
Anode material		Wolfram
Anode angle	°	12.5
Pulse/pause ratio		1:60 or more

4.1 X-ray tube performance data

Maximum Rating Charts

(Absolute maximum rating charts)

Focus Spot : 0.4 mm

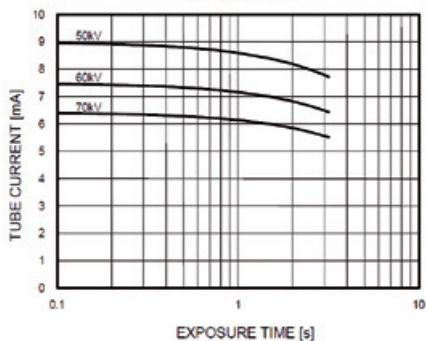

Emission & Filament Characteristics

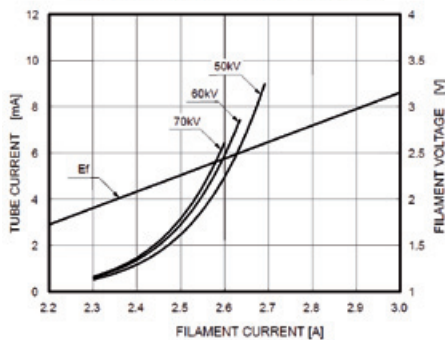

Anode Thermal Characteristics

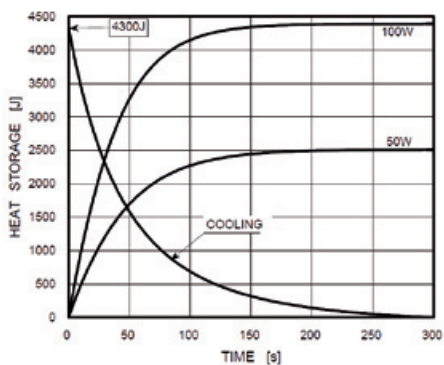

Monoblock Cooling Curve

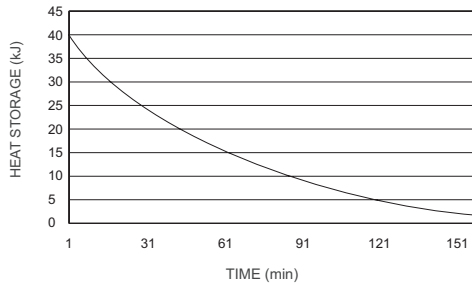

General technical data		2202-01	2202-02	2202-03
Arm length	mm	450	600	900
Total length	mm	1888	2038	2338
Weight	kg	24.4	26.4	28.4

Ambient conditions during operation

Temperature	°C	10 - 35
Relative humidity	%	30 - 75
Air pressure	hPa	860 - 1060

Ambient conditions during storage and transport

Temperature	°C	-10 to +60
Relative humidity	%	10 - 75
Air pressure	hPa	860 - 1060

4.2 Dimensions

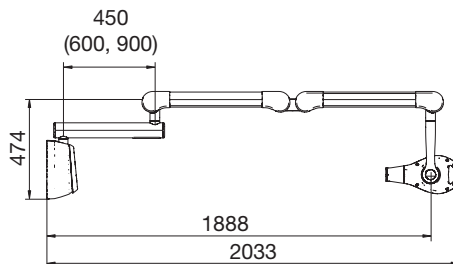

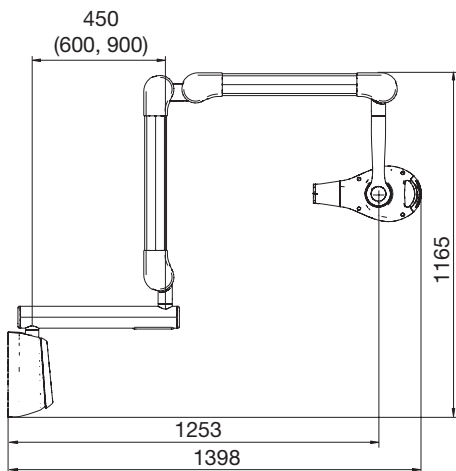
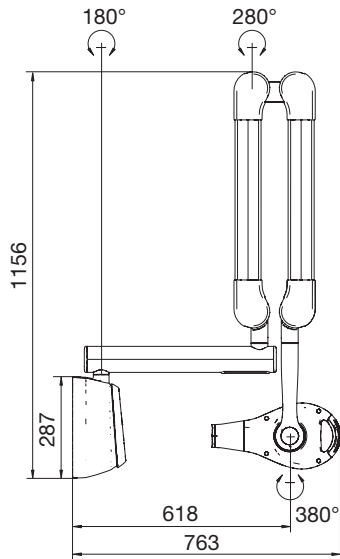

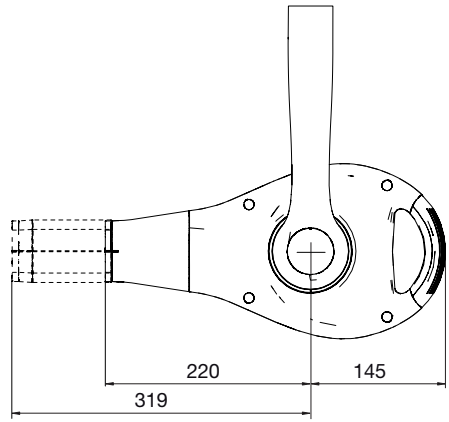

EN

4.3 Type plate

The type plates are located outside on the housing of the control unit and on the X-ray emitter.

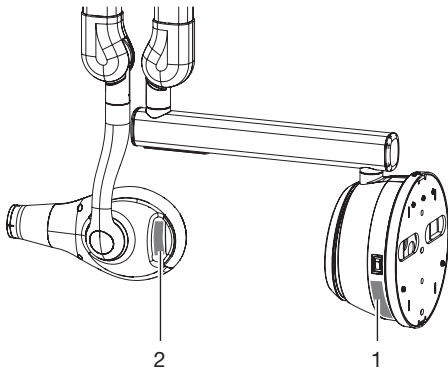

- 1 Unit type plate
- 2 X-ray emitter type plate

4.4 Conformity assessment

This device has been subjected to conformity acceptance testing in accordance with the current relevant European Union guidelines. This equipment conforms to all relevant requirements.

The Vistalutra DC has been developed and manufactured according to the following specifications:

- Protection against water penetration: Not protected: IPX0
- Protection against electric shock: Protection class I device, Type B application part

The CE mark declares that the product satisfies the applicable requirements according to Directive 93/42/EU for medical products.

5 Operation

The VistalIntra DC is an extraoral x-ray unit and is factory set at the correct x-ray dosage for each dental area required using Dürre Dental image plates and sensors. It consists of a control unit, the arm system and an X-ray unit.

The handle on the x-ray head unit allows the x-ray tube to be positioned precisely.

5.1 Control panel

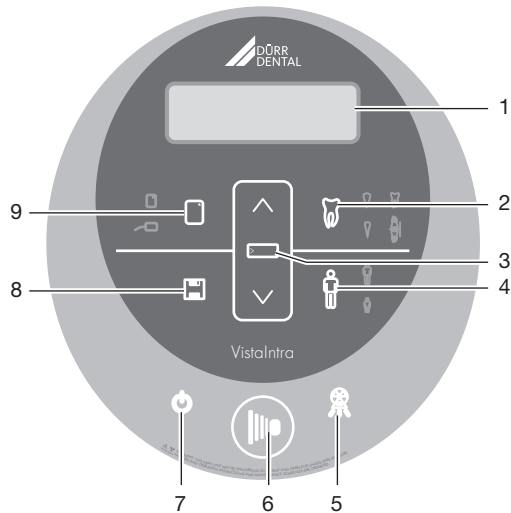

- 1 Display μGycm^2 , kV, mA, sec, Error
- 2 Selection of tooth symbol
- 3 Selection of X-ray parameter
- 4 Selection Adult/Child
- 5 Control lamp X-ray radiation
- 6 Trigger button
- 7 Stand-by display
- 8 Save button
- 9 Image plate/sensor selection

Selection of tooth symbol



Front tooth



Molars



Premolars





Bite wing exposure

Selection of X-ray parameter



kV -> mA -> sec

To input the following parameters, press the 
or  button

kV: 60 - 70, 50 - 70 (optional)

mA: 4 - 7

sec: 0.04 - 2



Selection Adult/Child



Adult



Child

Image plate/sensor selection



Image plate



Sensor

5.2 Exposure switch

The capture ring can be used as alternative to using the control panel to activate the irradiation.

5.3 Radiation field limitation

The radiation field collimation reduces the useful x-ray field to the required dimensions. This reduces the x-ray exposure of the patient. Comply with any national regulations.

5.4 Wall mounting plate

The wall mounting plate can be installed if required in order to ensure the holding forces of the fittings. The unit should be fixed to the wall mounting plate using the four screws provided.

5.5 Adapter plate

The adapter plate is mounted if necessary. The already available drill holes of products from other manufacturers are used for attaching. The unit is fixed to the adapter plate using the four screws provided.



Only qualified specialists or employees trained by Dürr Dental are permitted to install, connect and start using the unit.

6 Requirements

6.1 Installation/setup room

The room chosen for set up should fulfill the following requirements:

- Closed, dry room
- It should not be a room made for another purpose (e.g. boiler room or wet cell).
- Refer to the requirements for environmental conditions in "4 Technical data".

6.2 Information about electrical connections

- › Ensure that electrical connections to the mains power supply are carried out in accordance with current valid national and local regulations and standards governing the installation of low voltage units in medical facilities.
- › Install an all-pole disconnect switch with a contact opening width of at least 3 mm in the electrical connection to the mains power supply.
- › Observe the current consumption of the devices that are to be connected.

The diameter of the connections depends on the current consumption, length of line and the ambient temperature of the unit. Information concerning the current consumption can be found in the Technical Data supplied with the particular unit to be connected.

The following table lists the minimum diameters of the connections in relation to the current consumption:

Current consumption of unit [A]	Cross-section [mm ²]
> 10 and < 16	1.5
> 16 and < 25	2.5
> 25 and < 32	4
> 32 and < 40	6
> 40 and < 50	10
> 50 and < 63	16

Installation type	Line layout (minimum requirements)
Fixed installation	- Plastic sheathed cable (e.g. type NYM-J)
Flexible	- PVC flexible line (e.g. H05 VV-F) or - Rubber connection (e.g. H05 RN-F or H05 RR-F)

7 Installation

7.1 Installing the unit with the wall mounting bracket



Use a suitable fixing material for the substrate. The load bearing properties of the fixtures must guarantee sufficient security.

- › Fix the wall mounting plate to the wall using four screws and rawplugs.

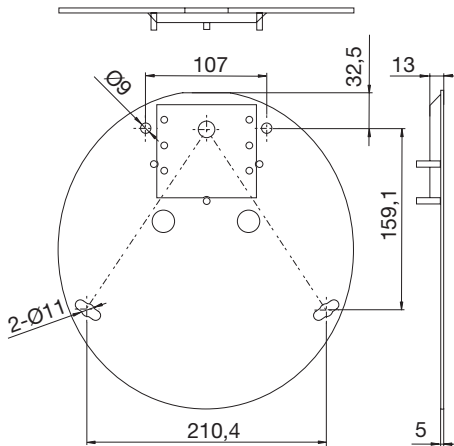

7.2 Secure unit with wall mounting plate



Use a suitable fixing material for the substrate. The load bearing properties of the fixtures must guarantee sufficient security.

- › Fix the wall mounting plate to the wall using four screws and rawplugs.

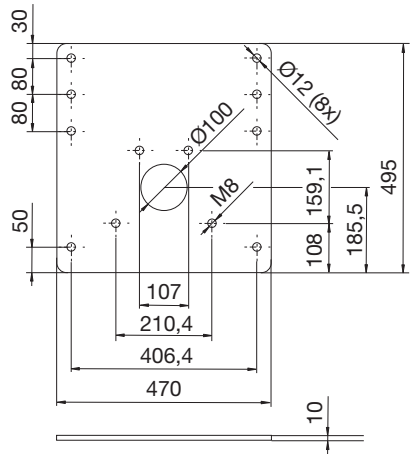

- › Fix the unit to the wall mounting plate using four M8 screws.

7.3 Mount radiation field collimation

- › Slide the radiation field collimation piece onto the tube and adjust according to the image plate or the sensor.

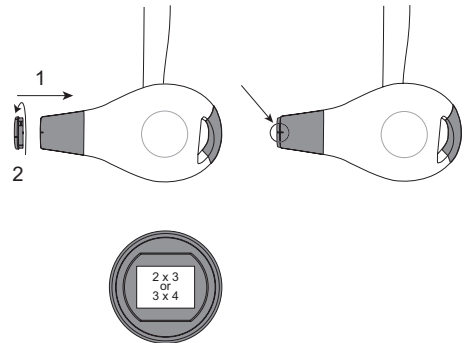

7.4 Electrical safety when making connections

- › Create a permanent electrical connection to the mains power supply in accordance with DIN EN 60601-1.
- › Make sure that none of the electrical cables leading to the unit are under any mechanical tension.
- › Before initial start-up check that the mains supply voltage and the voltage stated on the type plate match (see also "4. Technical data").

7.5 Connecting the unit to the mains

Requirements:

- Correctly installed mains cable available at the height of the wall mounting plate, or easily-accessible power outlet.
 - Mains voltage must match the information shown on the type plate of the power supply unit.
- › Connect up the lines.

8 Commissioning and first start-up



NOTICE

Short circuit due to the build up of condensation

- › Do not switch on the unit until it has warmed up to room temperature and it is dry.

The required tests (e.g. acceptance tests) must be carried out in accordance with local rules and regulations.

- › Find out which tests are required.
- › Carry out testing in accordance with local rules and regulations.

8.1 Acceptance test



The Intra / Extra Digital test body is required for acceptance tests with the image plate and sensor as receivers, and possibly also the corresponding test body holder.

- › Before the unit is started up and used for the first time, the acceptance test of the X-ray system must be carried out in accordance with national regulations.

The constancy tests, which must be carried out at regular intervals by the surgery personnel, are based on the results of the acceptance test.

8.2 Electrical safety checks

- › Carry out the electrical safety check according to the national law (e. g. in accordance with IEC 62353).
- › Document the results.

8.3 Switch on the unit





















The display will show the standard values for X-ray exposures or the setting values used for the last exposure carried out.

- Operational display lamps
- LED for tooth symbol selection
- LED for menu Adult/Child selection and the
- LED for image plate/sensor selection illuminate.

8.4 Service menu settings



All settings are saved after the first triggering.

- › While the  button is pressed, also press the  button longer in order to switch to the service menu.
- Browse in the menu with  or .
- Use  to select the respective menu option.
- › Under menu option 1. **Cone Type**, browse with  and confirm with .
- Use  to return to the Service menu.
- › Under menu option 2. **DAP Setting**, browse with  and confirm with .
- Use  to return to the Service menu.
- › Under menu option 3. **Default Value Reset**, confirm the resetting with .
- › Under menu option 4. **kV Option**, browse with  and confirm with ; 50-70 kV are only permitted for countries without restrictions of the German X-ray Act.
- › Under menu option 5. **X-ray Count**, browse with  and confirm with .
- › Under menu item 6. **Exposure Set**, make the relevant selection with  and confirm with .
- › The current firmware version can be read off under menu option 7. **Version**. Acknowledge with .
- › Under menu option 8. **Demo Mode** the demo version can be started by pressing the  button.
- › After inputting all values, exit the service menu with the  button.



9 Operation



NOTICE

Exerting force on the unit can lead to it becoming damaged

> Do not lean against or support yourself on the unit.

9.1 Standard settings after activation



The tube length can be preset in the Service-Menu "8.4 Service menu settings".

An extension of the tube influences the image quality and the dose area product displayed.

Standard settings after activation

- Last detector used
- Premolars
- Adult
- 60 kV
- 7 mA

The following table shows the standard values for the exposure time and the dose area product of an image plate for an adult patient.

	DC emitter, 7 mA Tube length 20 cm					
	Without X-ray field limitation		X-ray field limitation 2x3		X-ray field limitation 3x4	
	60 kV	mGycm ²	60 kV	mGycm ²	60 kV	mGycm ²
Incisors	0.08 s	14.6	0.08 s	3.1	0.08 s	6.2
Premolars	0.12 s	21.9	0.12 s	4.6	0.12 s	9.3
Molars	0.17 s	31.1	0.17 s	6.6	0.17 s	13.2
Bitewing	0.18 s	32.9	0.18 s	7.0	0.18 s	14

	DC emitter, 6 mA Tube length 30 cm					
	Without X-ray field limitation		X-ray field limitation 2x3		X-ray field limitation 3x4	
	70 kV	mGycm ²	70 kV	mGycm ²	70 kV	mGycm ²
Incisors	0.13 s	11.8	0.13 s	2.5	0.13 s	5.0
Premolars	0.18 s	16.4	0.18 s	3.4	0.18 s	6.9
Molars	0.25 s	22.8	0.25 s	4.8	0.25 s	9.6
Bitewing	0.27 s	24.6	0.27 s	5.2	0.27 s	10.4

The following table shows the standard values for the exposure time and the dose area product of an image plate for a child patient.

	DC emitter, 7 mA Tube length 20 cm					
	Without X-ray field limitation		X-ray field limitation 2x3		X-ray field limitation 3x4	
	60 kV	mGycm ²	60 kV	mGycm ²	60 kV	mGycm ²
Incisors	0.05 s	9.1	0.05 s	1.9	0.05 s	3.8
Premolars	0.07 s	12.8	0.07 s	2.7	0.07 s	5.4
Molars	0.11 s	20.1	0.11 s	4.2	0.11 s	8.5
Bitewing	0.11 s	20.1	0.11 s	4.2	0.11 s	8.5

	DC emitter, 6 mA Tube length 30 cm					
	Without X-ray field limitation		X-ray field limitation 2x3		X-ray field limitation 3x4	
	70 kV	mGycm ²	70 kV	mGycm ²	70 kV	mGycm ²
Incisors	0.08 s	7.3	0.08 s	1.5	0.08 s	3.1
Premolars	0.11 s	10.0	0.11 s	2.1	0.11 s	4.2
Molars	0.14 s	12.8	0.14 s	2.7	0.14 s	5.4
Bitewing	0.14 s	12.8	0.14 s	2.7	0.14 s	5.4

› Check and adjust the specific X-ray unit in accordance with the standard values.

The following table shows the standard values for the exposure times and the dose area product of sensors for an adult patient.

	DC emitter, 7 mA Tube length 20 cm					
	Without X-ray field limitation		X-ray field limitation 2x3		X-ray field limitation 3x4	
	60 kV	mGycm ²	60 kV	mGycm ²	60 kV	mGycm ²
Incisors	0.07 s	12.8	0.07 s	2.7	0.07 s	5.4
Premolars	0.10 s	18.3	0.10 s	3.8	0.10 s	7.7
Molars	0.13 s	23.8	0.13 s	5.0	0.13 s	10.1
Bite wing	0.14 s	25.6	0.14 s	5.4	0.14 s	10.8

	DC emitter, 6 mA Tube length 30 cm					
	Without X-ray field limitation		X-ray field limitation 2x3		X-ray field limitation 3x4	
	70 kV	mGycm ²	70 kV	mGycm ²	70 kV	mGycm ²
Incisors	0.11 s	10.0	0.11 s	2.1	0.11 s	4.2
Premolars	0.16 s	14.6	0.16 s	3.1	0.16 s	6.2
Molars	0.20 s	18.2	0.20 s	3.8	0.20 s	7.7
Bite wing	0.21 s	19.1	0.21 s	4.0	0.21 s	8.1

The following table shows the standard values for the exposure time and the dose area product of sensors of a child patient.

	DC emitter, 7 mA Tube length 20 cm					
	Without X-ray field limitation		X-ray field limitation 2x3		X-ray field limitation 3x4	
	60 kV	mGycm ²	60 kV	mGycm ²	60 kV	mGycm ²
Incisors	0.04 s	7.2	0.04 s	1.5	0.04 s	3.0
Premolars	0.06 s	10.9	0.06 s	2.3	0.06 s	4.6
Molars	0.08 s	14.6	0.08 s	3.1	0.08 s	6.2
Bite wing	0.09 s	16.4	0.09 s	3.4	0.09 s	6.9

	DC emitter, 6 mA Tube length 30 cm					
	Without X-ray field limitation		X-ray field limitation 2x3		X-ray field limitation 3x4	
	70 kV	mGycm ²	70 kV	mGycm ²	70 kV	mGycm ²
Incisors	0.07 s	6.4	0.07 s	1.3	0.07 s	2.7
Premolars	0.10 s	9.1	0.10 s	1.9	0.10 s	3.8
Molars	0.13 s	11.8	0.13 s	2.5	0.13 s	5.0
Bite wing	0.14 s	12.8	0.14 s	2.7	0.14 s	5.4

› Check and adjust the specific X-ray unit in accordance with the standard values.

Recommended exposure times for films with class E sensitivity on an adult patient.







	DC radiator, tube length 20 cm		DC radiator, tube length 30 cm	
	7 mA	6 mA	7 mA	6 mA
	60 kV	70 kV	60 kV	70 kV
Incisors	0.16 s	0.08 s	0.32 s	0.16 s
Premolars	0.20 s	0.10 s	0.40 s	0.20 s
Molars	0.25 s	0.12 s	0.50 s	0.25 s
Bite wing	0.32 s	0.16 s	0.64 s	0.32 s

Recommended exposure times for films with class E sensitivity on a child patient.

	DC radiator, tube length 20 cm		DC radiator, tube length 30 cm mA	
	7 mA	6 mA	7 mA	6 mA
	60 kV	70 kV	60 kV	70 kV
Incisors	0.10 s	0.05 s	0.20 s	0.10 s
Premolars	0.12 s	0.06 s	0.25 s	0.12 s
Molars	0.16 s	0.08 s	0.32 s	0.16 s
Bite wing	0.20 s	0.10 s	0.40 s	0.20 s

› Check and adjust the specific X-ray unit in accordance with the standard values.

Setting X-ray parameters

- > Press the image plate/sensor selection button.
- > Press the tooth symbol selection button.
- > Press the Adult/Child patient selection button.
- > Press the imaging parameters selection button
 - Select kV, with   other value
- > Press the imaging parameters selection button
 - Select mA, with   other value
- > Press the imaging parameters selection button
 - sec, select another value with  
- > Press Save button for 2 secs.

Result:

The individual settings have now been saved and can be read on the display.

-  To reset the unit to the factory settings please contact your Service Technician.

9.2 Positioning patient, X-ray unit and detector



CAUTION Injuries to the oral cavity

Sharp-edged detectors can cause injuries to the oral cavity.

- > Careful positioning of the detector into the patient's oral cavity.

- > Allow the patient to sit down.
- > Position the detector inside the oral cavity
- > Position the x-ray unit.



CAUTION Image data insufficient

If the x-ray unit is moved or if the patient moves during exposure then the image data will not be usable.

- > The patient should sit quite still during x-ray exposure.
- > The x-ray unit must not be moved in any way during exposure.

The detector can be any of the following:

- Film
- Sensor
- Image plate



Ensure that the detector is placed within the x-ray field.

Place the tube close to the skin.

Parallel technique

Position the detector using a holder system for parallel techniques (see leaflet "Image plates and film holder system" order number 2130100050L4x, contained on accompanying DVD).

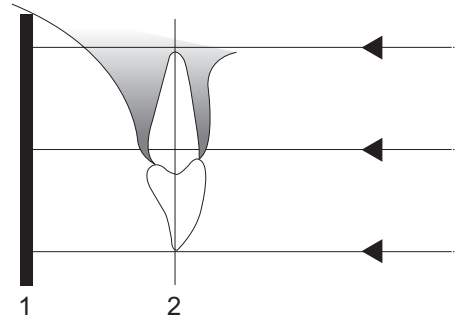

- 1 Detector
- 2 Tooth axis

Bisection angle technique

The patient should hold the detector in the mouth in the correct position. The middle of the radiation ray is set at right angles to an (estimated) plane at half the angle between tooth axis and detector.

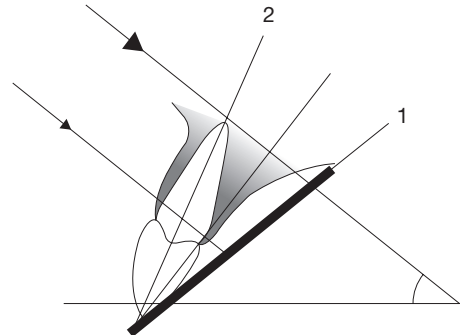

- 1 Detector
- 2 Tooth axis

Upper jaw front tooth exposure

X-ray is projected 45° downwards

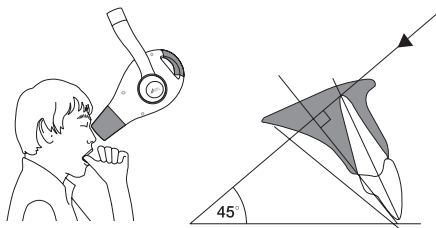

Lower jaw front tooth exposure

X-ray is projected 25° upwards

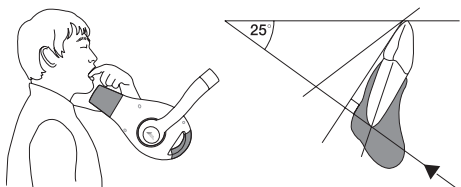

Upper jaw molar and premolar exposure

X-ray is projected 30° downwards

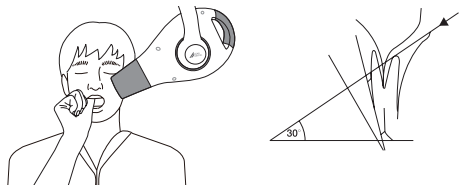

Lower jaw molar and premolar exposure

X-ray is projected 5° upwards

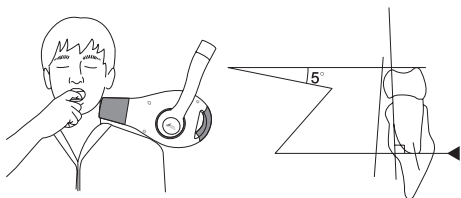

Bite wing technique

During the bite wing exposure the patient needs to bite on a bite wing holder.

X-ray is projected 5 to 8° upwards

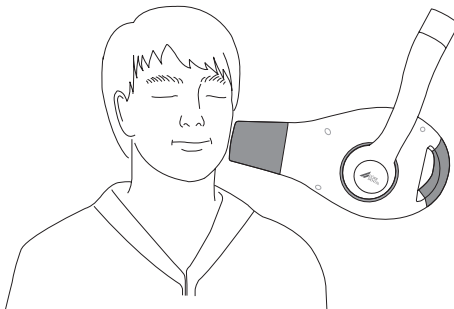

9.3 Trigger the capturing of the image



CAUTION Injuries through x-rays

- X-rays can cause tissue damage.
- Comply with the radiation protection regulations.
- Maintain the minimum distance.



- 1 Display
- 2 Selection of tooth symbol
- 3 Selection of X-ray parameter
- 4 Selection Adult/Child
- 5 Control lamp X-ray radiation
- 6 Trigger button

**NOTICE****Unit damage due to switching frequency being too high**

If sufficient cooling of the x-ray unit is not ensured, this can lead to damage to the unit.

- › Only activate the subsequent x-ray image after the displayed cooling time has elapsed.

- › Check x-ray settings on control panel and change if necessary
 - Change the tooth region using tooth symbol selection button
 - Change to adult or child using patient selection key
- › Check x-ray parameter and set if necessary
- › Press the trigger button
 - The x-ray unit control lamp lights green -> unit is warming up
 - The control lamp lights orange and an acoustic signal is heard -> unit is exposing



Hold the trigger button at least as until the acoustic signal stops. Otherwise the exposure will be faulty and there will be an error message in the display.

- The image is ready as soon as the exposure time has passed. The X-ray unit control lamp goes out and the acoustic signal is no longer heard.
- The dose area product is shown on the display, when this function is enabled in the service menu.



The unit cools down after every exposure. The cooling time is counted down on the display. During this time, the trigger button can no longer be operated. The X-ray unit control lamp blinks.

- The unit is ready again.

10 Cleaning and disinfection

**NOTICE****The use of unsuitable agents and methods can damage the unit and accessories.**

- › Only use the disinfectants and cleaning agents specified or approved by Dürr Dental.
- › Comply with the specifications contained in the operating instructions of the disinfectants and cleaning agents.



Wear safety gloves.



Prior to working on the device or in case of danger, disconnect it from the mains (e. g. pull the mains plug).

The unit surface must be cleaned and disinfected of any contamination or soiling. Use the following cleaning and disinfectant agents:

- FD 322 rapid surface disinfectant
- FD 333 rapid surface disinfectant
- FD 350 disinfectant wipes

**NOTICE****Liquid can cause damage to the unit.**

- › Do not spray the unit with cleaning and disinfectant agents.
- › Make sure that liquid does not get inside the unit.

- › Remove any soiling with a soft, wet, lint-free cloth.
- › Disinfect the surfaces using a disinfection wipe. Alternatively, use a spray disinfectant on a soft, lint-free cloth. Comply with the operating instructions for the disinfectant when doing this.

11 Maintenance

11.1 Recommended maintenance schedule

 The following must be noted when performing maintenance work.

- › The unit and the accessories required for its use must only be set up in a dry room. It must be ensured for the long term that the equipment remains in good condition.
- › The operation of the device can be influenced by factors such as temperature, light, ventilation, dust, salt etc.
- › All of the utensils required to take an X-ray should be carefully positioned to enable an effective workflow.
- › Check that the unit has an earth connection.
- › Do not fix the unit or cables yourself. This could lead to injuries or to damage to the unit.

 Prior to working on the device or in case of danger, disconnect it from the mains (e. g. pull the mains plug).

Inspection interval	Inspection work
Daily	<ul style="list-style-type: none"> › Clean all device components that the patient or operator may come into contact with "10 Cleaning and disinfection". › Between patients wipe down the surface of the device with a moist, soft, lint-free cloth "10 Cleaning and disinfection". › Functional test of the exposure button including status LED and acoustic signal. › Make sure that the mains cable is properly installed "7.4 Electrical safety when making connections". › Make sure that no mineral oil is leaking from the X-ray emitter. › Make sure that the wall mounting is properly secured. › Make sure that the mains cable and plug are not hot. › Make sure that there is no damage to the mains cable "7.4 Electrical safety when making connections". › Make sure that the main power switch is switched off when the device is no longer in use.
Weekly	<ul style="list-style-type: none"> › Make sure that there is no damage to the mains cable "7.4 Electrical safety when making connections".
Monthly	<ul style="list-style-type: none"> › Make sure that all information signs and the type plates on the unit are undamaged and clearly legible. › Make sure that the unit is properly earthed. › Make sure that there is no damage to the cable of the exposure switch.



12 Tips for operators and service technicians



Any repairs above and beyond routine maintenance must only be carried out by suitably qualified personnel or by one of our service technicians.

Fault	Probable cause	Solution
E01	Electrical connection between the control panel and PCB (main board) is interrupted	<ul style="list-style-type: none"> › Switch off the unit. › Check the connection cable. › Inform a service technician.
E02	Electrical connection interrupted between X-ray emitter and PCB (main board)	<ul style="list-style-type: none"> › Switch the unit off and on. › Inform a service technician.
E03	Current exceeds maximum permitted value during exposure	<ul style="list-style-type: none"> › Switch the unit off and on. › Inform a service technician.
E04	Voltage exceeds maximum permitted value during exposure by ± 10 kV	<ul style="list-style-type: none"> › Switch the unit off and back on. › Inform a Service Technician.
E05	Current exceeds maximum permitted value during exposure by ± 0.5 mA	<ul style="list-style-type: none"> › Switch the unit off and back on. › Inform a Service Technician.
E06	Voltage exceeds maximum permitted value during exposure by ± 20 kV	<ul style="list-style-type: none"> › Switch the unit off and back on. › Inform a Service Technician.
E07	Voltage exceeds maximum permitted value during exposure by ± 1 mA	<ul style="list-style-type: none"> › Switch the unit off and back on. › Inform a Service Technician.
E08	X-ray emitter temperature too high	<ul style="list-style-type: none"> › Switch off the unit until the X-ray emitter has cooled down. › Switch the unit back on again.
E09	Current outside permitted range during exposure	<ul style="list-style-type: none"> › Switch the unit off and on. › Inform a service technician.
E10	X-ray exposure not activated despite the exposure trigger button being pressed	› Acknowledge the error by pressing the "X-ray Parameter Selection" button for 10 seconds or restart the unit.
E11	Exposure for longer than 0.5 seconds, even though the trigger button is no longer being pressed	<ul style="list-style-type: none"> › Switch off the unit. › Inform a service technician.
E12	Displayed kV value is lower than the set value	<ul style="list-style-type: none"> › Switch the unit off and on. › If the fault continues to be displayed, inform your Service Technician.

Fault	Probable cause	Solution
E13	Displayed kV value is higher than the set value	<ul style="list-style-type: none"> › Switch the unit off and on. › If the fault continues to be displayed, inform your Service Technician.
E14	Displayed mA value is lower than the set value	<ul style="list-style-type: none"> › Switch the unit off and on. › If the fault continues to be displayed, inform your Service Technician.
E15	Displayed mA value is higher than the set value	<ul style="list-style-type: none"> › Switch the unit off and on. › If the fault continues to be displayed, inform your Service Technician.
E60	Trigger button is permanently pressed	<ul style="list-style-type: none"> › Disconnect and reconnect the exposure switch. Ensure that the trigger button is not pressed. › Inform a Service Technician.
E61	The trigger button is released before the set exposure time has been reached	<ul style="list-style-type: none"> › Acknowledge the error by pressing the "X-ray Parameter Selection" button or restart the unit. › If the fault repeat, inform your Service Technician.
Value over	Operating error kV value or time entered is too high	<ul style="list-style-type: none"> › Correct the value.

Fault	Probable cause	Solution
Unit does not switch on	No mains voltage	<ul style="list-style-type: none"> › Check the mains cable and plug connection and replace if necessary. › Inform a service technician.
	On/off switch is defective	<ul style="list-style-type: none"> › Check the mains fuse in the building.
No X-rays emitted	X-ray emitter temperature too high	<ul style="list-style-type: none"> › Wait until the x-ray emitter has cooled down.
	The trigger button on the control panel is defective	<ul style="list-style-type: none"> › Inform a service technician.
	The trigger button on the capture ring is defective	<ul style="list-style-type: none"> › Cable is defective or not connected to unit. › Inform a service technician.

Fault	Probable cause	Solution
X-ray image too bright	Detector being used not compatible with the unit settings	› Wait until the x-ray emitter has cooled down.
	X-ray emitter incorrectly positioned	› Correct the position of the X-ray emitter
	X-ray parameters set incorrectly	› Check X-ray parameters and adjust if necessary. Increase the exposure time. › Inform a service technician.
	Detector not correctly positioned in the mouth of the patient	› Correct the position of the detector
X-ray image too dark	Detector being used not compatible with the unit settings	› Use a different detector or change the unit settings.
	X-ray parameters set incorrectly	› Check X-ray parameters and adjust if necessary. Reduce the exposure time. › Inform a service technician.



13 Information about EMC in accordance with EN 60601-1-2

13.1 General information

The information in this leaflet includes excerpts from the relevant European standards for electrical, medical devices. It must be observed when installing Dürr Dental devices or combining them with products of other manufacturers. If you are uncertain about anything, please refer to the complete standard.

13.2 Abbreviations

EMC	Electromagnetic compatibility
HF	High frequency
U_T	Rated voltage of the device (supply voltage)
V_1, V_2	Compliance level for the test in acc. with IEC 61000-4-6
E_1	Compliance level for the test in acc. with IEC61000-4-3
P	Rated power of the transmitter in Watts (W) in accordance with the specifications of the transmitter manufacturer
d	Recommended safety distance in meters (m)

13.3 Guidelines and manufacturer's information

Electromagnetic emissions for all devices and systems

The device is designed for operation in an electromagnetic environment as specified below. The customer or operator of the device should ensure that the device is operated in such an environment.

Interference emission measurements	Compliance	Electromagnetic environment - guidelines
HF emissions in accordance with CISPR 11	Group 1	The unit uses HF energy exclusively for internal functions. As a result, HF-transmissions are very low and it is highly unlikely that any interference will be caused to neighbouring electronic devices.
HF emissions in accordance with CISPR 11	Class A	The Vistalnta DC is suitable for use in facilities other than living areas and those areas that are directly connected to the PUBLIC MAINS ELECTRICITY SUPPLY that also supplies buildings used for residential purposes.
Harmonics in acc. with IEC 61000-3-2	Not applicable	
Voltage fluctuations/flickers in acc. with IEC 61000-3-3	Not applicable	

Resistance to electromagnetic interference (immunity) for all devices and systems

The device is designed for use in electromagnetic environments specified below. The customer or operator of the device should ensure that the device is operated such an environment.

Interference immunity tests	IEC 60601 - test level	Compliance level	Electromagnetic environment - guidelines
Electrostatic discharge (ESD) in acc. with IEC 61000-4-2	±6 kV contact discharge ±8 kV air discharge	±6 kV contact discharge ±8 kV air discharge	Floors should be made of wood or cement, or covered with ceramic tiles. If the floor is covered by synthetic material, then the relative humidity must be at least 30%.
Electrical fast transient/burst immunity test in accordance with IEC 61000-4-4	±2 kV for mains cables ±1 kV for input and output cables	±2 kV for mains cables ±1 kV for input and output cables	The quality of the supply voltage should correspond to a typical commercial or hospital environment.
Voltage surge in accordance with IEC 61000-4-5	±1 kV voltage outer conductor/outer conductor ±2 kV voltage outer conductor/earth	±1 kV push-pull voltage ±2 kV common mode voltage	The quality of the supply voltage should correspond to a typical commercial or hospital environment.
Voltage drops, short-term interruptions and fluctuations of the supply voltage in accordance with IEC 61000-4-11	< 5% U_T (> 95% drop in U_T) for 1/2 period 40% U_T (60% drop in U_T) for 5 periods 70% U_T (30% drop in U_T) for 25 periods < 5% U_T (> 95% drop in U_T) for 5 s	< 5% U_T (> 95% drop in U_T) for 1/2 period 40% U_T (60% drop in U_T) for 5 periods 70% U_T (30% drop in U_T) for 25 periods < 5% U_T (> 95% drop in U_T) for 5 s	The quality of the supply voltage should correspond to a typical commercial or hospital environment. If the operator of the device needs the unit to continue working even if the mains power supply is interrupted, we recommend powering the device from an uninterruptible power supply (UPS) or from a battery.
Magnetic field for a supply frequency (50/60 Hz) in accordance with IEC 61000-4-8	3 A/m	3 A/m	The magnetic fields at mains frequency should be within the range of typical values encountered in a commercial or hospital environment.

Table 1: Resistance to electromagnetic interference (immunity) for all devices and systems

Electromagnetic interference immunity for devices or systems that are not life-sustaining

Portable and mobile communication devices should not be used any closer to the unit (including cables) than the recommended safety distance, which is calculated based on the applicable formula for the transmission frequency.

Interference immunity tests	IEC 60601 - test level	Compliance level	Recommended safety distance
Conducted HF disturbance variables in accordance with IEC 61000-4-6	$3 V_{\text{eff}}$, 150 kHz to 80 MHz	$[V_1] = 3 \text{ V}$	$d = [3.5 / V_1] \cdot \sqrt{P}$
Emitted HF disturbance variables in accordance with IEC 61000-4-3	3 V/m 80 MHz to 2.5 GHz	$[E_1] = 3 \text{ V/m}$	$d = [3.5 / E_1] \cdot \sqrt{P}$ for 80 MHz to 800 MHz $d = [7 / E_1] \cdot \sqrt{P}$ for 800 MHz to 2.5 GHz

P Rated power of the transmitter in Watts (W) in accordance with the specifications of the transmitter manufacturer

d Recommended safety distance in meters (m)



The field strength of stationary communication devices should be lower than the compliance level for all frequencies based on inspections on site^{a, b}. Interference is possible in the environment of units that have the following symbols.

Comment 1 The higher frequency range applies for 80 MHz and 800 MHz.

Comment 2 These guidelines may not apply in all cases. The propagation of electromagnetic radiation is affected by absorption and reflection on the building, objects and people.

^a The field strength of stationary transmitters, such as the base stations of mobile phones and land mobile radios, amateur radio stations, AM and FM radio and television broadcasters, for example, cannot be accurately predicted. In order to determine the electromagnetic environment with regard to stationary transmitters, a study of electromagnetic phenomena at the site should be considered. If the measured field strength at the location where the unit is used exceeds the compliance levels stated above, the unit should be monitored to verify that it works as intended. If unusual performance characteristics are observed additional measures may be required, such as a changing the orientation of the unit or moving it to a different location.

^b Over the frequency range of 150 kHz to 80 MHz, the field strength should be less than $[V_1]$ V/m.

Recommended safety distance between portable and mobile HF communication devices and the unit

The device is designed for use in the electromagnetic environments specified below, in which the HF disturbance variables are controlled. The customer or the operator of the device can help to prevent electromagnetic interference by maintaining the minimum distances between mobile HF communication equipment (transmitters) and the device as recommended below in accordance with the maximum output line of the communication equipment.

Rated power of the transmitter (W)	Safety distance based on the transmission frequency (m)		
	150 kHz to 80 MHz $d = 1.2 \cdot \sqrt{P}$	80 MHz to 800 MHz $d = 1.2 \cdot \sqrt{P}$	800 MHz to 2.5 GHz $d = 2.3 \cdot \sqrt{P}$
0.01	0.12	0.12	0.23
0.1	0.38	0.38	0.73
1	1.2	1.2	2.3
10	3.8	3.8	7.3
100	12	12	23

Table 2: Recommended safety distance between portable and mobile HF communication devices and the unit

For transmitters whose maximum rated power is not specified in the table shown above, the recommended safety distance d in meters (m) can be determined from the formula that belongs to the respective column where P is the maximum rated power of the transmitter in Watts (W) in accordance with the specifications of the transmitter manufacturer.

Comment 1 The higher frequency range applies for 80 MHz and 800 MHz.

Comment 2 These guidelines may not apply in all cases. The propagation of electromagnetic waves is affected by absorption and reflection on the building, objects and people.

13.4 Calculation table

If the measured values deviate from the standard, the values are specified in chapter "Electromagnetic emissions for all devices and systems".

The safety distances can then be calculated in the tables shown below.

- P:
- V_1 :
- E_1 :

- P Rated power of the transmitter in Watts (W) in accordance with the specifications of the transmitter manufacturer
- V_1 Compliance level for the test in acc. with IEC61000-4-6
- E_1 Compliance level for the test in acc. with IEC61000-4-3

Interference immunity tests	IEC 60601 - test level	Compliance level	Recommended safety distances
Conducted HF disturbance variables in accordance with IEC 61000-4-6	$3 V_{\text{eff}}$ 150 kHz to 80 MHz	$[V_1] V$	$d = [3.5 / V_1] \cdot \sqrt{P}$
Emitted HF disturbance variables in accordance with IEC 61000-4-3	3 V/m 80 MHz to 2.5 GHz	$[E_1] V/m$	$d = [3.5 / E_1] \cdot \sqrt{P}$ for 80 MHz to 800 MHz $d = [7 / E_1] \cdot \sqrt{P}$ for 800 MHz to 2.5 GHz

Rated power of the transmitter (W)	Safety distance based on the transmission frequency (m)		
	150 kHz to 80 MHz $d = [3.5/V_1] \cdot \sqrt{P}$	80 MHz to 800 MHz $d = [3.5/E_1] \cdot \sqrt{P}$	800 MHz to 2.5 GHz $d = [7 / E_1] \cdot \sqrt{P}$
0.01			
0.1			
1			
10			
100			



Hersteller/Manufacturer:

VATECH Co. Ltd.
13, Samsung 1-ro 2-gil
Hwaseong-si, Gyeonggi-do,
18449
Korea
Fon: +82 31 323 8639
www.vatech.co.kr

Vertreiber/Distributor:

DÜRR DENTAL SE
Höpfigheimer Str. 17
74321 Bietigheim-Bissingen
Germany
Fon: +49 7142 705-0
www.duerrdental.com
info@duerrdental.com

